

HB-510N/P

Driver Card Manual

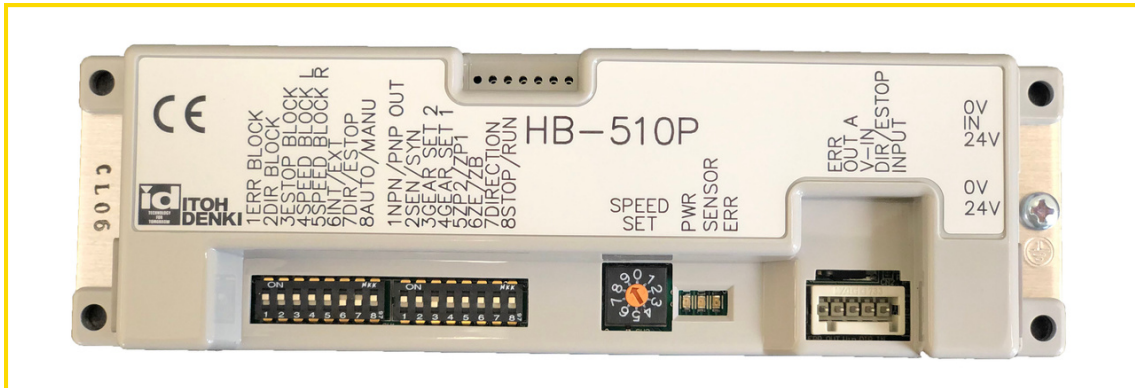

WHAT'S NEW:

- Designed to be functional with the FS and FE series motors, as well as the higher torque series FP
- Run Hold timer added to the Forcible RUN input
 - Now there is no need for an external controller/timer with, or awkward positioning of, a second sensor used for infeding the conveyor
- Integral indexed rotary switch provides easy speed adjustment without the need for “tweaking”
- More LED functionality to communicate operating and error statuses
- Selectable automatic or manual recovery for thermal overload protection
- Motor lock protection shuts motor down if it is locked for at least 4 seconds
- Lead free design for RoHS conformity

FEATURES:

- Logic for general zero pressure accumulation (ZPA) control is built-in
- Direct connection for a photo-sensor to both power it and receive its output signal
- Easy connection between adjacent HB-510s with communication cables simplifies wiring
- Selectable singulated or slug (train) release modes for ZPA function
- Flexible Zone Recognition (patented) to handle long articles which simultaneously block multiple sensors
 - Only available in slug release mode
- Synchronized speed variation to simultaneously adjust the speed of the rollers with a single external speed control signal
- Stable speed function to ensure that different weight articles travel at the same rate
 - As long as the load does not exceed the rated torque for a given speed
- Enclosure is made from fire resistant ABS

Specifications subject to change without notice

SUBJECT	PAGE
Features	
-What's New	1
-General Features	
Table of Contents	2
Specifications	
-Dimensions	3
-User Interface	
-Standard Conveyor Figuration	
Connections	4-6
Installation Precautions	7-8
Switch Settings	
-Signal Blocking	
-Input/Output Settings	
-Timer Settings	9-17
-Other Settings	
-Speed Adjustment	
-Jumper Settings	
LED and Error Indications	
-Solution	18
Conveyor Zone Configuration	19-22
Connecting to HB-508S	23-25
Using HB-510 as a Driver/Slave Card	26
Revision History	27

DIMENSIONS:

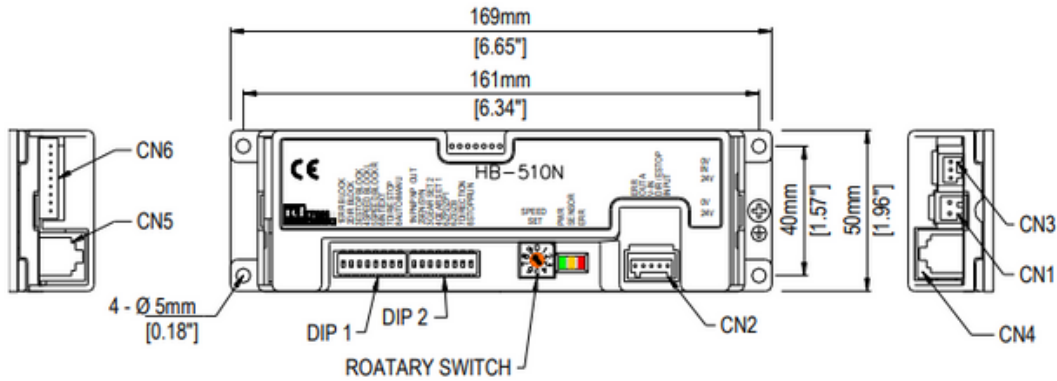

USER INTERFACE (DEFAULT SETTINGS):

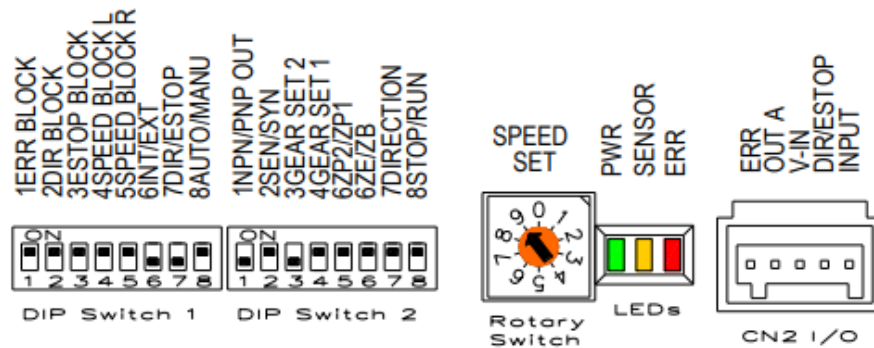

STANDARD CONVEYOR CONFIGURATION - NPN OUTPUT SIGNAL TYPES:

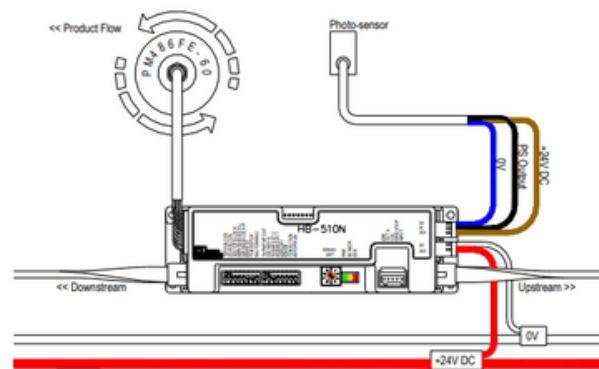

CN1	2 PIN Connector for Power	Male Connector on Card WAGO #734-162	Female Connector for Wiring WAGO #734-102
PIN	Description		
1	+24V DC $\pm 10\%$ (full-wave rectified, smoothed current $< 10\%$ ripple)		Wire Size 28~14AWG
2	0V		

CN2	(Ordered Separately) 5 PIN connector for External Control	Male Connector on Card WAGO #733-335	Female Connector for Wiring WAGO #733-105
PIN	Description		
1	+24V DC or 0V output (ERR – open collector: 25mA max)		Wire Size 28~20AWG
2	+24V DC or 0V output (OUT A – open collector: 25mA max)		
3	0~+10V DC input (V-IN)		
4	+24V DC or 0V input (DIR/E-stop)		
5	+24V DC or 0V input (INPUT)		

CN3	3 PIN connector for Sensor	Male Connector on Card WAGO #733-363	Female Connector for Wiring WAGO #733-103
PIN	Description		
1	+24V DC		Wire Size 28~20AWG
2	+24V DC or 0V (sensor signal input)		
3	0V		

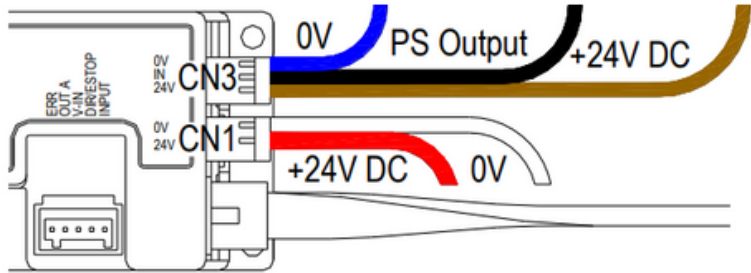

CONNECTION INSTRUCTIONS FOR CN1, CN2, & CN3:

- Press down spring clamp in connector with a small screwdriver.
- Insert leads in proper order. (Lead should be stripped approx: 0.31~0.35")
- WAGO connector must be inserted and/or pulled out carefully, so as not to damage other parts.

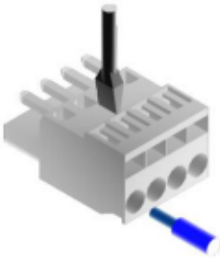

CN4 & CN5		8 PIN Connector for Communication Cable	Male Connector on Card Molex #52018-8845	Female Connector for Wiring RJ-45
CN4 PIN	CN5 PIN	Description		
1	2	Sensor signal output		Wire Size: 26AWG or Equivalent 8 wire cable
2	1	Sensor signal input		
3	3	Speed variation signal		
4	4	Error signal		
5	6	Drive input		
6	5	Drive output		
7	7	Direction signal		
8	8	Emergency stop signal		

COMMUNICATION CABLE - STRAIGHT-THROUGH WIRING:

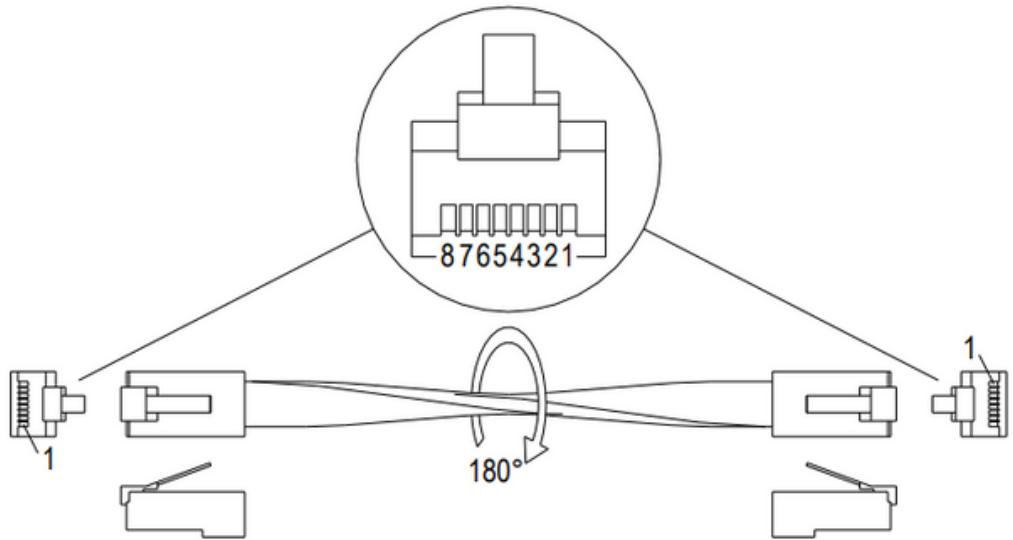

■ This straight through cable is intended for use between HB-510 cards. Please refer to the section **Connect to HB-508S** for further instruction when using HB-510 with HB-508S cards.

CN6	9 or 10 PIN connector for Motor	Male Connector on Card JST #S?B-XH-A (? = 9 or 10)	Female Connector for Wiring JST #XHP-? (? = 9 or 10)
PIN	Description		
1	GND – Grey		<p>Wire size: 28~22AWG & 24~22AWG motor phases</p> <p>Terminal Pins: JST #SXH-001T-P0.6</p>
2	+12V DC – Blue		
3	Motor phase U – Red		
4	Motor phase V – White		
5	Motor phase W – Black		
6	Hall sensor U - Violet		
7	Hall sensor V – Orange		
8	Hall sensor W – Green		
9	Thermistor – Light Blue		
10	Brake - Yellow		

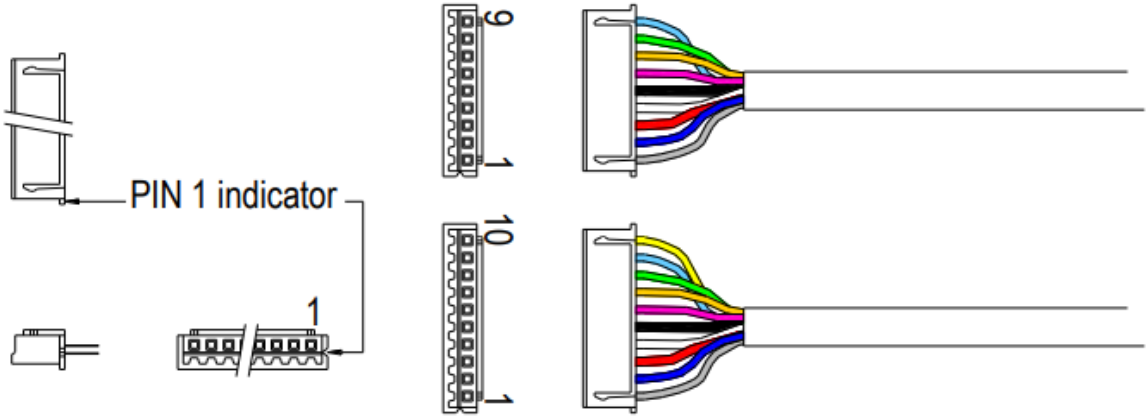

INSTALLATION PRECAUTIONS



IMPORTANT: PLEASE READ BEFORE INSTALLATION

Precaution	Action	Reason
Sensor	Use a sensor that would have an active output when the zone is occupied Example: A retro-reflective photosensor would need to be dark-operate	-The HB-510 responds to the active signal received from the sensor to denote zone occupation. If the incorrect type is used, the HB-510 would “think” that a zone is occupied when it is really clear. Not only would there be problems in ZPA logic operation, but there will also be JAM errors appearing.
More than 30 cards connected together with the communication cable	The first card after each set of 30* must be set as follows: DIP Switch 1-1: OFF DIP Switch 1-2: OFF DIP Switch 1-3: OFF *Standard conveyor configuration; starting with first upstream card. If using any of these signals, they need to be connected to this point as well.	-When a card has its ERR, DIR, or ESTOP signal activated, that signal is communicated through the communication cable by sinking the signal. Because of this, that card’s circuitry must be able to handle the current sourced by the other cards. When there are more than 30 cards, the signal’s current level is too high and will damage the card’s circuitry
Restarting the system after applying ESTOP signal	Wait until sufficient time has passed before removing the ESTOP signal from the system.	-RUN Hold Timer continues to operate even after the ESTOP signal is applied. If the signal is removed before the timer times out, an article will begin to move downstream. This may cause a collision of articles
	Make sure transported articles are not between photo-sensors.	-Any article between photo-sensors will not be recognized as occupying a zone. Therefore, any upstream articles being transported may collide into them.
Powering ON	Keep away from the system when it is first powered ON.	-When the system is first powered ON and there is no signal from the photo-sensor for presence of an article, the zone will RUN for a short time at a slow speed to receive or advance any articles which may be between photo-sensors. There may be a risk for bodily injury because of moving rollers and transported articles.
	As a standard driver card, connect the sensor input (CN3-2) to 0V (NPN) or to 24V (PNP) to provide a constant “sensor ON” signal.	-Used in conjunction with DIP switch 2-6 (OFF/ZE). This eliminates the power ON running sequence. Please see page 24.
Correct Cables	RJ-45 connectors 8-wire cables Straight-through wiring pattern	-Straight-through wiring means that the connectors on both ends of the cable are wired in the exact same pattern. -Cross-over wiring or any other wiring pattern will cause communication problems.

INSTALLATION PRECAUTIONS



IMPORTANT: PLEASE READ BEFORE INSTALLATION

Precaution	Action	Reason
Compatibility with HB-508S	Please refer to the section: Connecting to HB-508S	SPEED, DIR, and E-STOP/GND signals will conflict
Low impedance connection to PNP output(s)	DO NOT connect an output terminal (CN2-2, CN2-1) set for PNP directly to 0V, GND, or a low impedance input on a controller	When the PNP signal is active, the low impedance input will draw a high current and subsequently damage the output circuit. Damage may also occur to the input circuit on the controller.
Multiple power supplies	0V line of all power supplies on the same conveyor line (powering the card/rollers, & controls) need to be physically linked together	This completes the signal path from one section of the conveyor (powered by a power supply) to the adjacent section of conveyor (powered by another power supply) and allows for proper communication through the cable and external interfaces.
Voltage drop across the power bus	Use suitable gauge wire in relation to distance and current draw to prevent voltage drop. Operating DC voltage is 24V \pm 10%	When running long distances from a DC power supply, the voltage drop during motor operation across the power bus may be significant (may drop below 15V). If there is a large enough drop in voltage, the roller(s) may behave in a strange manner. In order to prevent this, a larger gauge wire must be used.
Grounding	Ensure the control card is securely grounded to the conveyor frame. The conveyor frame should also be at the same potential reference as earth ground. Standard grounding practices should be followed.	Static discharge may interfere and damage internal components.
Environment	Ambient temperature is 32~104°F Ambient humidity is < 90% RH Atmosphere has no corrosive gas Vibration is < 0.5G - Indoor use only	Extreme environmental variables may cause poor or no performance and damage the card.
Electrical	24V DC \pm 10% 4A maximum current limiter (motor lock is 4A) Diode protection for miswiring Sensor power short circuit protection 5A fuse for power supply protection Auto-sensing inputs for PNP or NPN	Improper power will damage the card. The motor/ card should not be subject to locked conditions repeatedly. Internal fuse is not replaceable. If the fuse has blown, more serious damage has occurred within the card/motor. If inputs are subjected to a low potential the card may see this as a signal, use of a diode inline is recommended to prevent this.
Over-Speeding	Over-speeding of the roller's no-load speed by more than 50% may cause damage.	Back EMF will be generated.

SIGNAL BLOCK SETTINGS:

DIP Switch	Function	ON		OFF		Default Setting
		CN5 (Left)	CN4 (Right)	CN5 (Left)	CN4 (Right)	
1-1	ERR signal transmission	Transmit & Receive	Transmit & Receive	Transmit & Receive	Blocked	ON
1-2	DIR signal transmission				Blocked	ON
1-3	ESTOP signal transmission				Blocked	ON
1-4	SPEED signal transmission Left (Downstream)	n/a	n/a	Blocked	n/a	ON
1-5	SPEED signal transmission Right (Upstream)	n/a	Transmit & Receive	n/a	Blocked	ON

- Signal blocking is independent from the ZPA logic direction (which can be reversed with the DIR signal)
- Signal blocking occurs on the right-hand side communication port (CN4) when looking at the card in normal orientation
- Signals will always be transmitted or received from the left-hand side communication port (CN5).
 - The exception to this design is the SPEED signal which can be blocked on both CN4 & CN5

ILLUSTRATION: SIGNAL BLOCKING:

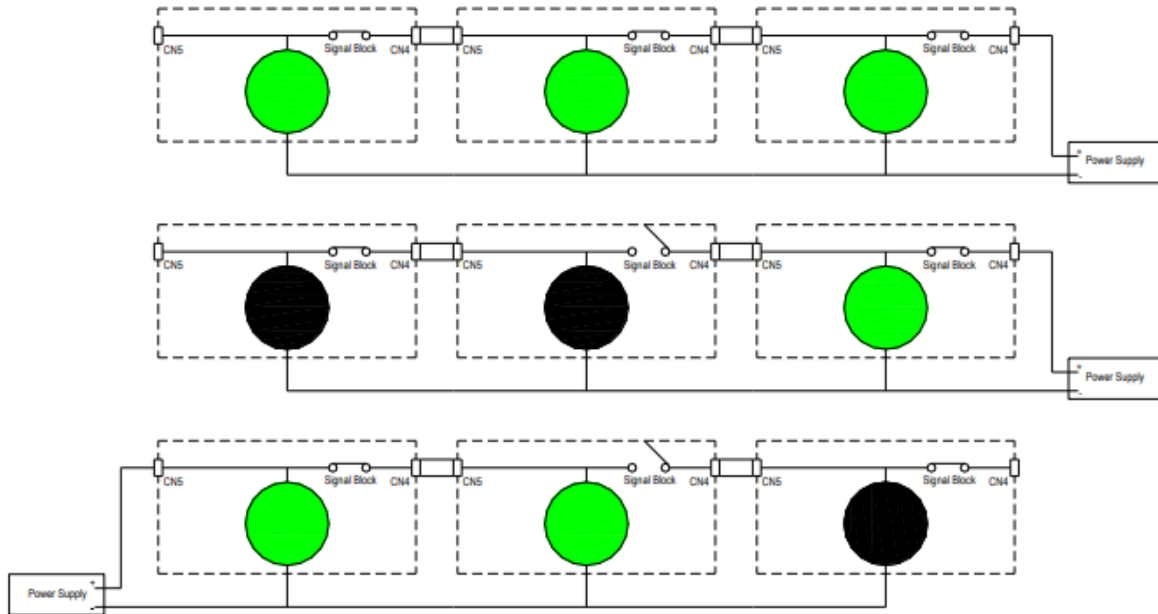

- Dashed box represents HB-510. The circle is a light (green=ON; Black=OFF). The “signal” for the lights is being provided by the power supply
- The uppermost case is a signal being provided from the right-hand side (CN4). In this case the DIP switch is ON for transmit/receive
- The middle case is the same set-up as the upper case, but with the center card’s DIP switch OFF. Note that the signal is blocked at CN4
- The bottom case is the same set-up as the middle case, but with the signal from the left-hand side. Note the difference in the light response when the signal is coming from the other side

INPUT/OUTPUT SETTINGS:

DIP Switch	Function	ON	OFF	Default Setting
1-6	SPEED adjustment	External: 0~10V DC	Internal: Rotary switch	OFF
1-7	DIR or ESTOP input (CN2-4)	ESTOP signal input	DIR signal input	OFF
1-8	Reset for thermal recovery	Manual input recovery	Automatic recovery	ON
2-1	Output signal type (CN2-2 & CN2-1)	PNP signal output	NPN signal output	OFF
2-2	Sensor or Synchronous output (CN2-2)	Output is active while internal motor RUN signal is ON	Output is active while photo-sensor (CN3-2) signal is ON.	ON
2-8	STOP or RUN input (CN2-5)	RUN signal input	STOP signal input	ON

DIP Switch 1-6: Speed adjustment can be controlled by two methods

- To control the speed on an individual card
 - DIP switch 1-6 must be OFF
 - Rotary switch must be used to adjust speed
 - Rotary switch setting is independent of transmitted SPEED signal
 - Rotary switch setting will not have any effect on other cards
- To control the speed simultaneously on more than one card
 - DIP switch 1-6 must be ON for all cards being controlled by SPEED signal
 - SPEED signal (0~10V DC) applied to CN2-3 on 1 (one) card

DIP Switch 1-7: Direction (DIR) and emergency stop (ESTOP) signals cannot be applied to the same card

- If both signals need to be used
 - Set DIP switch 1-7 OFF for one card and input the DIR signal to CN2-4 on the same card
 - Set DIP switch 1-7 ON for another card and input the ESTOP signal to CN2-4 on the same card

INPUT/OUTPUT SETTINGS (CONTINUED):

DIP switch 1-8: Reset for thermal recovery

- Manual recovery (MANU; ON)
 - Some form of user intervention is needed to reset the thermal protection
 - The temperature of the motor or card must be in operating range in order for the recovery to work
 - Remove power (CN1) to the card, then reapply – most likely case o Input a signal to CN2-5 and have DIP switch 2-8 set ON for forcible RUN
 - The roller may operate while this signal is active, especially if the downstream zone is clear
 - Input a signal to CN2-4 and have DIP switch 1-7 set ON for ESTOP
 - This will send an ESTOP signal through the communication cable to all the connected cards
 - ESTOP Signal blocking may be necessary in order to not affect the adjacent zones
- Automatic recovery (AUTO; OFF)
 - The card will automatically reset the thermal protection once it or the motor has cooled to operating temperature

DIP switch 2-1: Output signal type for both CN2-2 (OUT A) & CN2-1 (ERR)

- When the signal is not active, there is no voltage present
 - NPN (OFF) – when active the output will be 0V
 - PNP (ON) – when active the output will be +24V DC
 - Do not connect to a low impedance input, 0V, or GND

DIP switch 2-2: Sensor or Synchronous output (CN2-2)

- Sensor (SEN; OFF) – OUT A is active while the output from the photo-sensor is active
- Synchronous (SYN; ON) – OUT A is active while the internal RUN signal (for motor operation) is active
 - This signal is usually used to slave drive another card/powered roller

DIP switch 2-8 – Forcible Stop or Run (CN2-5)

- Forcible STOP (OFF) – Prevents an article from advancing downstream once the present zone (while receiving the signal) becomes occupied
- Forcible RUN (ON) – Forces the present zone to RUN (while receiving the signal) under these conditions:
 - When DIP switch 2-6 is set ON (ZB) – Allows the present unoccupied zone to RUN until it becomes occupied
 - This setting does not override accumulation logic
 - If the zone is already occupied and stopped, it will not RUN
 - RUN Hold timer has been added to this input and setting to alleviate the need of an external controller/timer with an infeed photo-sensor. Therefore, once an article clears the photo-sensor connected to this input (CN2-5), the present zone will continue to operate and allow the article to reach the present zone's photo-sensor (CN3).
 - When DIP switch 2-6 is set OFF (ZE) – present zone will RUN (occupied or unoccupied) as long as the signal is present
 - Use this setting if the card is being used as a regular driver/slave card (no photo-sensor)

TIMER SETTINGS:

DIP Switch		Gear Stages	Time* (s)		
2-3	2-4		Sensor Timer	Run Hold Timer	Jam Timer
OFF	OFF	1	0.3~1.2	0.3~1.2	0.6~2.2
OFF	ON	2	1.0~4.0	1.0~4.0	2.0~8.0
ON	OFF	3	4.0~14.0	4.0~14.0	7.5~27.0
ON	ON	N/A	Motor runs continuously; troubleshooting purposes only		

* Time range is also dependent on the rotary switch position (i.e. higher position = shorter timing)

- A range of time should be selected for use. In most applications, the default setting should suffice. However, if longer or shorter times are necessary, select the appropriate DIP switch settings
- Because the roller speed may be affected by the rotary switch position, it is suggested that the speed required be set first, then the timing adjusted by use of these DIP switches

Sensor Timer: controls the RUN time of the motor during the zone's infeed operation in the ZPA system

- Present zone must receive signals through the communication cable from the upstream zone to function
- Present zone will RUN when
 - Present zone's photo-sensor is clear or Upstream zone's photo-sensor becomes blocked
 - Also, it sends a RUN signal to the present zone
- Sensor Timer starts when
 - Present zone is running due to the condition above
 - AND the upstream zone's photo-sensor becomes clear
 - If a jam occurs in the upstream zone
 - Sensor Timer never starts
 - Present zone will stop when upstream zone's Jam Timer reaches set time
- Sensor Timer will STOP the present zone when
 - Present zone is running and its photo-sensor remains clear
 - AND Sensor Timer reaches the set time
- Sensor Timer is RESET when
 - o It reaches the set time
 - Present zone's photo-sensor becomes blocked
 - Upstream zone's photo-sensor becomes blocked again

TIMER SETTINGS (CONTINUED):

Run Hold Timer: controls the RUN time of the motor during the zone's discharge operation in the ZPA system

- Present zone will RUN when
 - Present zone's photo-sensor is blocked
 - Downstream zone's photo-sensor is clear
 - This also applies if there is no downstream zone connected
- Run Hold Timer starts when
 - Present zone is running and its photo-sensor becomes clear
- Run Hold Timer will STOP the present zone when
 - Present zone is running and its photo-sensor remains clear
 - AND Run Hold Timer reaches the set time
- Run hold Timer is RESET when
 - It reaches the set time
 - Present zone's photo-sensor becomes blocked
 - Upstream zone's photo-sensor becomes blocked

Jam Timer: controls the RUN time of the motor during the zone's running operation in the ZPA system

- Jam Timer starts when
 - Present zone is running and its photo-sensor becomes blocked
- Jam Timer will STOP the present zone when
 - Present zone is running and its photo-sensor remains blocked
 - AND Jam Timer reaches the set time
- Jam Timer is RESET when
 - Present zone's photo-sensor becomes clear
 - Downstream zone's photo-sensor becomes blocked

OTHER SETTINGS:

DIP Switch	Function	ON		OFF		Default Setting
2-5	Release modes	ZP1 Train/Slug release		ZP2 Singulated release		ON
2-6	Last zone mode	ZB Standard zone		ZE Last zone		ON
2-7	Motor direction*	FE	FS/FP	FE	FS/FP	ON
		CCW	CW	CW	CCW	

* Motor direction (as viewed from the cable side; PM486 series) is independent of ZPA logic flow direction.

DIP switch 2-5 – Release modes

- ZP2 (OFF) – In singulated release mode (assuming accumulated conveyor) each zone will advance when its downstream zone is unoccupied
- ZP1 (ON) – In train/slug release mode (assuming accumulated conveyor) all zones will advance in unison

DIP switch 2-6 – Last zone mode

- ZB (ON) – Standard zone (zone beginning) mode
 - ZPA logic in this mode must receive a signal to prevent an article from advancing past the present zone
 - Through the communication cable from a downstream card
 - From an external control to the INPUT on CN2-5 and DIP switch 2-8 set OFF
- ZE (OFF) – Last zone (zone end) mode
 - ZPA logic in this mode stops an article in the present zone
 - Downstream ZPA communication is overridden

SPEED ADJUSTMENT:

Integral Indexed Rotary Switch	External Speed Variation Signal V ±0.2	Speed*	
		m/min ±3%	ft/min ±3%
9	9.5	60	196.8
8	8.5	55	180.4
7	7.5	50	164.0
6	6.5	45	147.6
5	5.5	40	131.2
4	4.5	35	114.8
3	3.5	30	98.4
2	2.5	25	82.0
1	1.5	20	65.6
0	0.5	15	49.2

* Card controls speed through motor RPM feedback

- Roller surface speed is dependent on a combination of motor RPM, gear-staging, and roller diameter
- This table is based on a PM486FE-60 roller which has 2 stage gearing, a 1.9in diameter tube, and motor RPM which is adjustable through the entire selectable range
- If a motor is a slower speed, and all other factors remain the same, any settings above the motor's top speed will have no effect
 - For example: PM486FE-20 will reach its maximum speed at setting 2. Any higher settings (3~9) will have no effect on its speed

NPN/PNP INPUTS:

- The card(s) are ordered with the inputs preset from the factory – ALL NPN or ALL PNP. The model designation will show the factory preset.
 - HB-510N – NPN input type (Default)
 - HB-510P – PNP input type
 - HB-510BN – NPN input type for brake card (Default)
 - HB-510BP – PNP input type for brake card
- If it is necessary to change the input type, the internal dip switch will need to be changed as shown below:

1. Pry open the plastic cover at screwdriver slots on front of the card



2. Adjust internal dip switch to appropriate setting and replace cover

Position for Signal Type		Initial Setting
NPN Setting	PNP Setting	
Up	Down	Up



- Note – the output can be manually switched in the field by DIP switch 2-1 – Output signal type for both CN2-2 (OUT A) & CN2-1 (ERR)
 - When the signal is not active, there is no voltage present
 - NPN (OFF) – when active the output will be 0V
 - PNP (ON) – when active the output will be +24V DC

LED AND ERROR INDICATIONS

Symptom	LED1 (green)	LED2 (orange)	LED3 (red)	ERR Signal (CN2-1)	Cause	Effect	Solution*
Normal	● (ON)		● (OFF)	● (ON)	n/a	n/a	n/a
	●● Blinks (1Hz) while running						
Thermal Overload		● (ON) When sensor signal is ON	● (ON)	● (OFF)	Motor or PCB above operating temperature	No Operation	1
Motor Stops	● (ON)		●● Blinks (1Hz)	● (ON)	Motor locked (≥4s)		2
Motor Unplugged			● (ON)		Motor is not connected to card		3
JAM Error		●● Blinks (1Hz)	● (OFF)	● (OFF)	Jam Timer activated		4
Open Fuse Low Voltage	● (OFF)	● (ON) When sensor signal is ON	●● Blinks (1Hz)		Low voltage or current exceeded 5A		5
Current Limit	●● Blinks (1Hz) while running		●●●● Blinks (6Hz)	● (ON)	High Current Draw		n/a

*SOLUTION:

- See more information under Input/Output Settings, DIP switch 1-8
 - A signal applied to CN2-5 (INPUT) will reset this error status
 - Thermal overload can only be reset if the temperature has fallen back into operating range
- Remove the cause of the motor lock and clear the zone
 - A signal applied to CN2-5 (INPUT) AND DIP switch 2-8 set to ON (RUN) will reset this error status
- Remove power from the card, plug in the motor connector, and then reapply power
- Remove the cause of the jam and clear the zone
 - A signal applied to CN2-5 (INPUT) will reset this error status
 - As long as a signal is applied to CN2-5, jam error status will not turn ON
- Replace the card
- Not usually a cause for concern, unless it is occurring frequently over the entire running cycle

CONVEYOR ZONE CONFIGURATION

STANDARD ZONE:

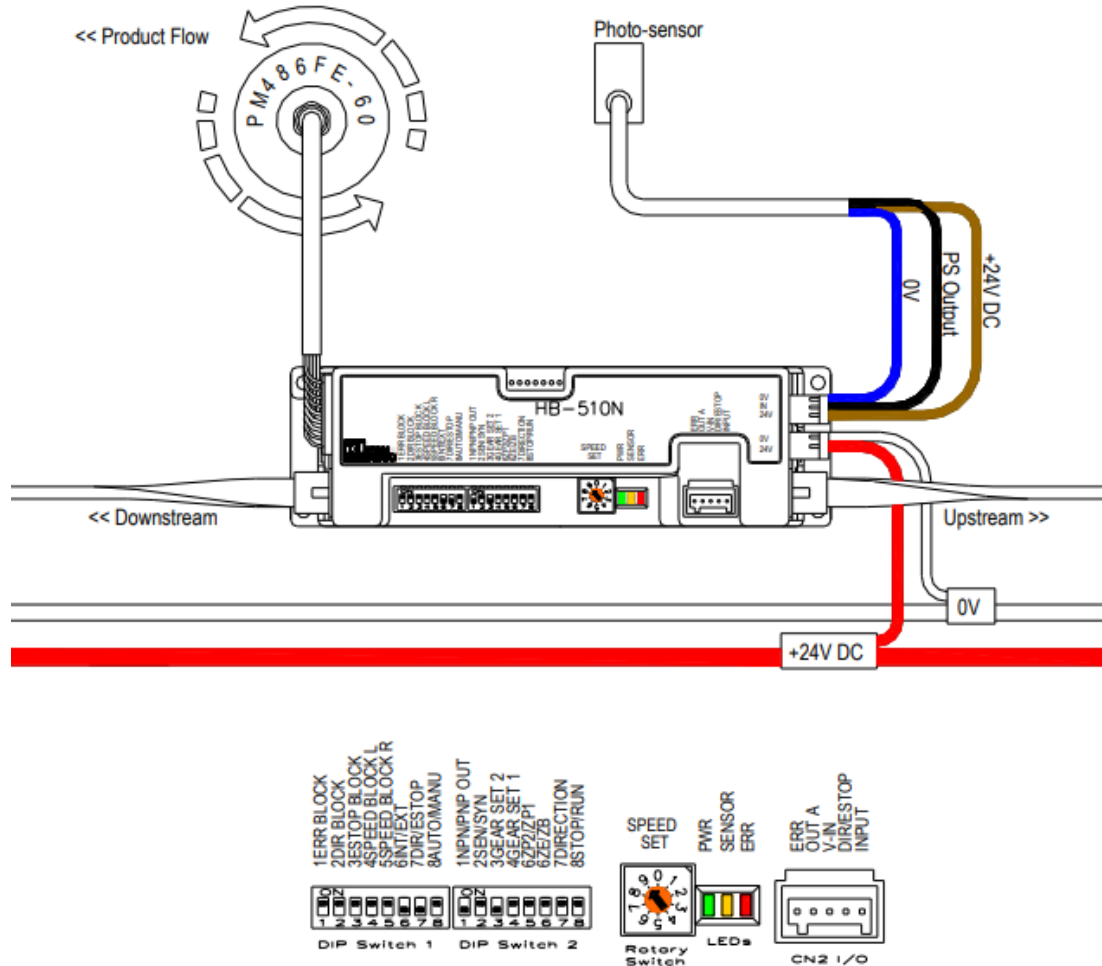

- This configuration (factory set) is the standard set-up for any zone that is not specifically an infeed or discharge zone.

CONVEYOR ZONE CONFIGURATION

INFEED ZONE:

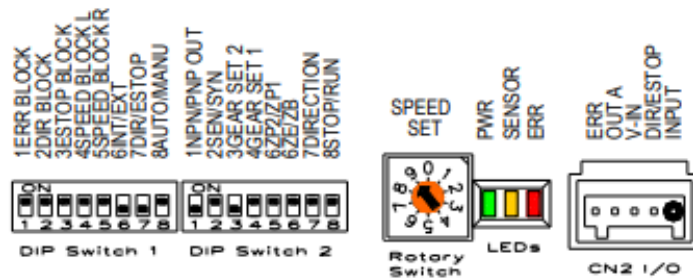
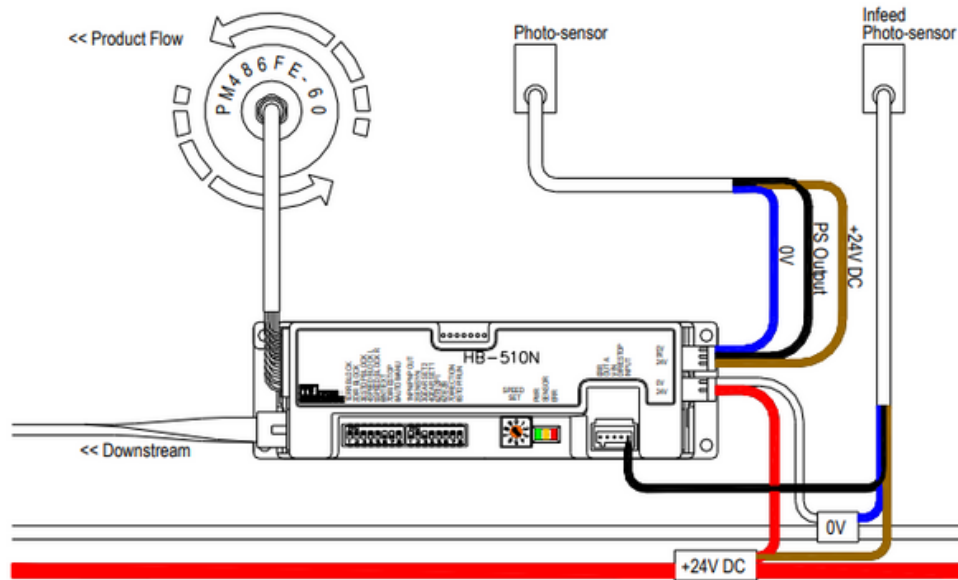

- The infeed zone can use 2 photo-sensors
 1. Main photo-sensor
 2. Infeed photo-sensor
- Set up
 - Card is in standard configuration
 - Distance between the infeed photo-sensor and the main photo-sensor should be set the same distance that is between all the adjacent zone photo-sensors
 - Photo-sensor is powered from the 24V DC bus
 - Output from infeed photo-sensor is connected to INPUT (CN2-5)
- The infeed RUN hold timer is active when INPUT (CN2-5) is being used while the card is set for ZB (DIPSW 2-6). There is no need for an external controller in these simple infeed applications.

CONVEYOR ZONE CONFIGURATION

DISCHARGE 1 ZONE:

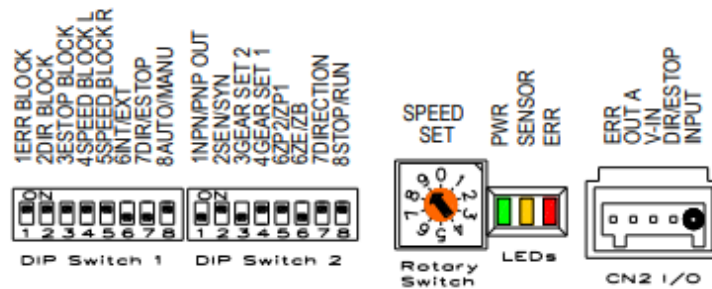
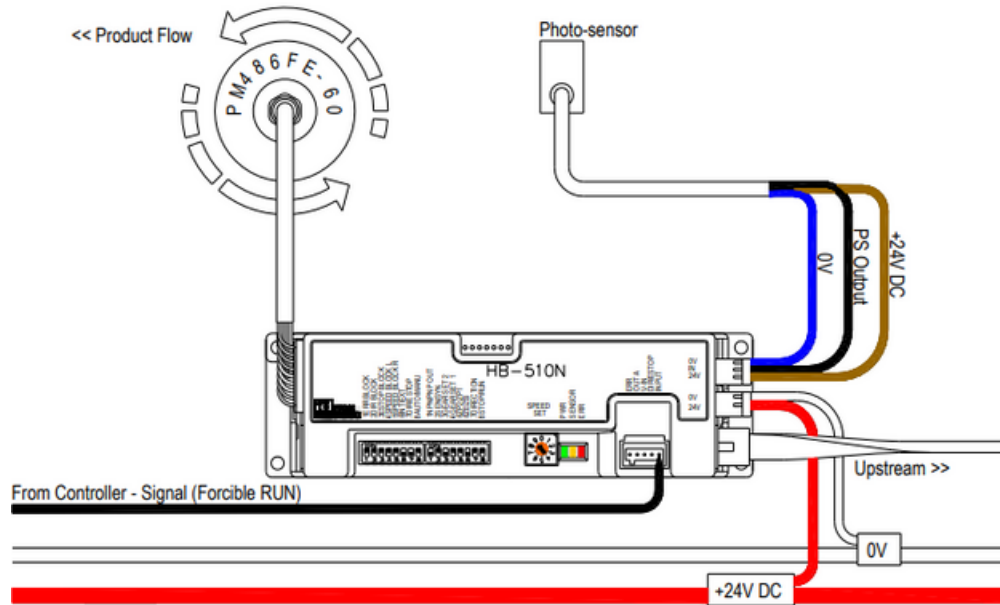

- The card is in standard orientation.
- Discharge 1 is applied when an article is to accumulate once it reaches the last HB zone. An external signal from a control is used only when discharging (force to RUN) of the article is needed.
- The signal from the controller will be applied to INPUT (CN2-5). The card will be set for ZE (DIPSW 2-6) & RUN (DIPSW 2-8). All other DIP switches can remain at default.
- There is no timing function applied to this configuration. The external discharge signal must remain active until the article has completely exited the zone (or cleared the photo-eye). Whenever the discharge signal is not active, the zone will stop and accumulate whenever an article is present.

CONVEYOR ZONE CONFIGURATION

DISCHARGE 2 ZONE

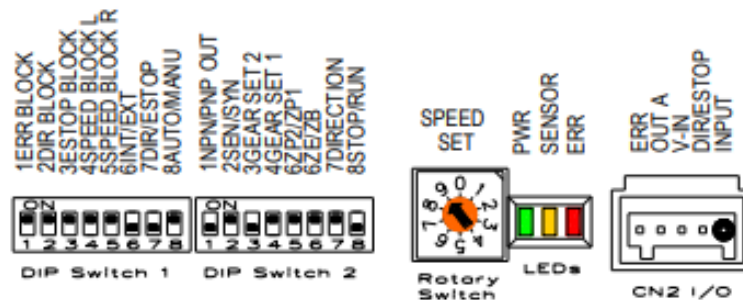
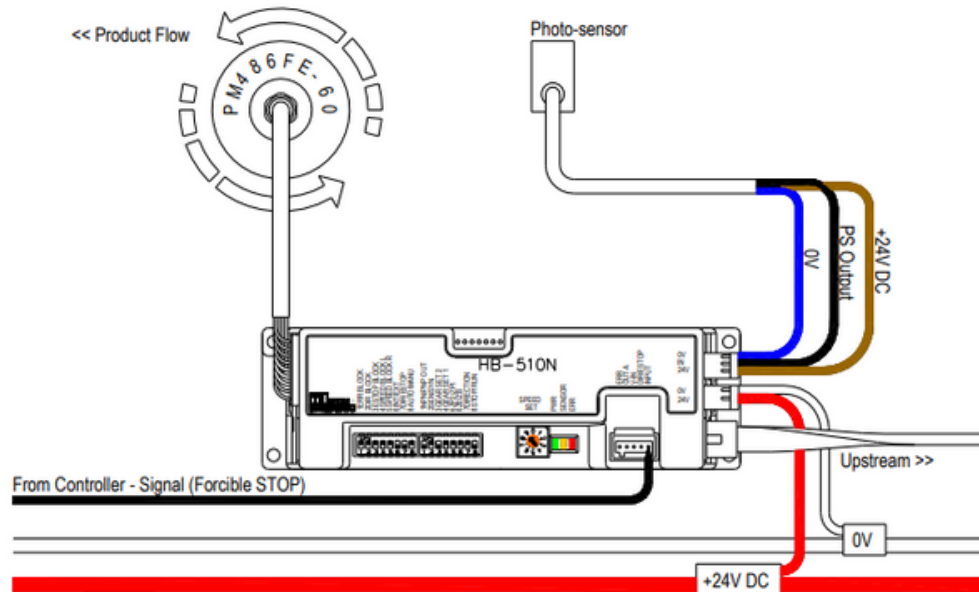

- The card is in standard orientation.
- Discharge 2 is applied when an article is to continuously discharge through the last HB zone. An external signal from a control is used only when accumulation (force to STOP) of the article is needed.
- The signal from the controller will be applied to INPUT (CN2-5). The card will be set for ZB (DIPSW 2-6) & STOP (DIPSW 2-8). All other DIP switches can remain at default.
- There is no timing function applied to this configuration. The external accumulation signal must remain active all the while the article is to be accumulated. Whenever the accumulation signal is not active, the last HB zone will run and discharge whenever an article is present.

OPTION 1 – COMMUNICATION CABLE MODIFICATION (RECOMMENDED)

Between any HB-508S and HB-510

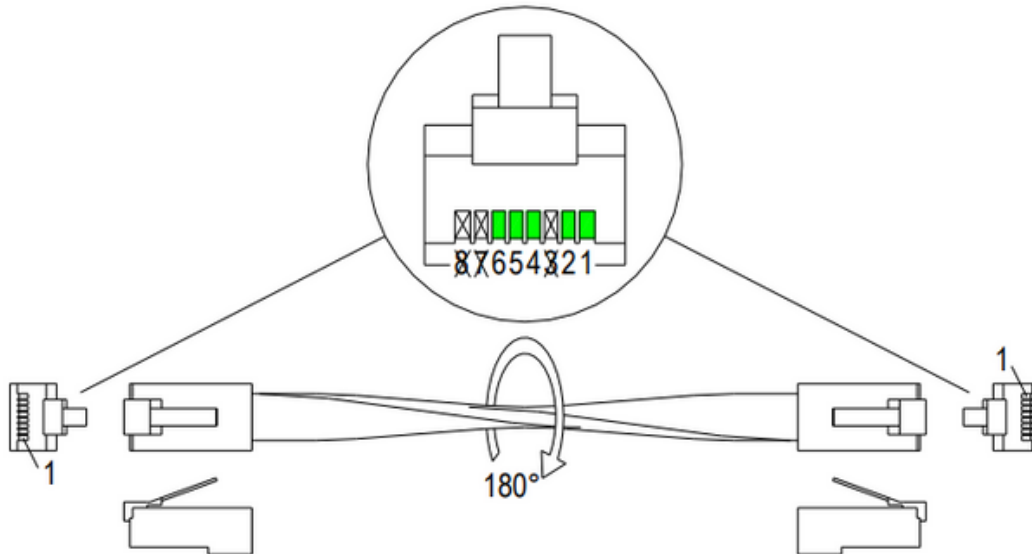

- When connecting an HB-510 to an HB-508S (upstream or downstream) a special cable is recommended. This modification can be easily performed when making the communication cable. Simply disable (or cut) PINS 3, 7, and 8 according to the above diagram on the communication cable.
- PIN 3 is the SPEED Variation Signal for both the HB-508S and the HB-510. However, the initial signal voltage is 0V for the HB-510. Which, when connected to an HB-508S, pulls the speed signal low and affects the HB-508S roller speed. If this connection is not disabled, the HB-508S will operate at a slower speed.
- PIN 7 is the DIR (direction) Signal for both the HB-508S and the HB-510. However, due to differing voltage levels, an HB-508S will pull the DIR signal low and affect the HB-510's roller direction.
- PIN 8 is the E-STOP Signal for the HB-510, but it is the GND for the HB-508S. The GND (0V) will pull the ESTOP signal low and stop HB-510 operation

* Regardless of the method used to connect the HB-510 to the HB-508S, there will always be a break in the SPEED and DIR signal communication between these two models. Therefore, if external speed or direction control is necessary, those signals will need to be repeated at the point(s) of the break(s).

OPTION 2 – HB-508S CN5 TO HB-510 CN4 (MODIFIED CABLE NOT NECESSARY)

HB-510 downstream from HB-508S in standard orientation

This is not necessary if a modified communication cable (option 1) is used.

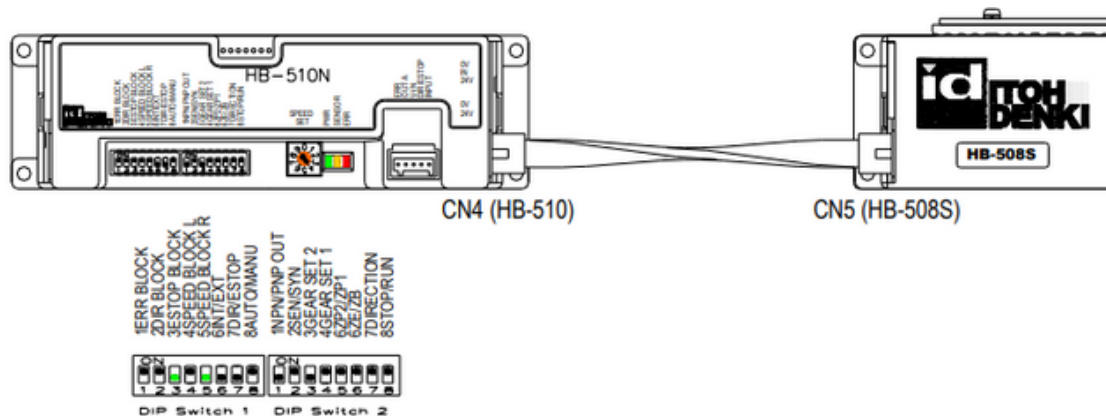

- The cards are in standard orientation.
- When connecting an HB-510 from CN4 to CN5 of an HB-508S, DIP Switch settings must be set to ensure compatibility.
- DIP Switch 1-2 DIR BLOCK must be OFF. This will prevent the communication of the direction signal to/from CN4 on the HB-510. If not set, this signal will be pulled low and thus activated due to the signal voltage level difference of the HB-508S.
- DIP Switch 1-3 E-STOP BLOCK must be OFF. This will prevent the communication of the E-STOP signal to/from CN4 on the HB-510. If not set, this signal will be pulled low and thus activated due to the 0V present from the HB-508S GND connection.
- DIP Switch 1-5 SPEED BLOCK R must be OFF. This will prevent the communication of the SPEED signal to/from CN4 on the HB-510. If not set, this signal will pull the speed signal in the HB-508S low and thus prevent the HB-508S to run at full speed.

Attention:

Option 2 or 3 may be used when connecting a chain of HB-508S cards to a chain of HB-510 cards. However, if an HB-510 card(s) is in between a chain of HB-508S cards, both Option 2 & 3 must be used. Because this may lead to confusion as to DIP switch settings and cable configuration, Option 1 is strongly recommended for all cases.

OPTION 3 – HB-510 CN5 TO HB-508S CN4 (PARTIALLY MODIFIED CABLE NECESSARY)

HB-508S downstream from HB-510 in standard orientation

This is not necessary if a modified communication cable (option 1) is used

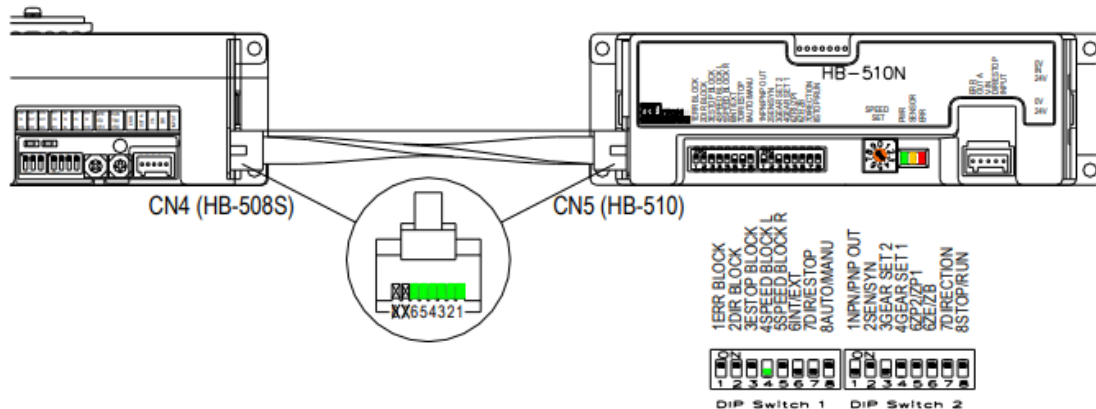

- When connecting an HB-508S from CN4 to CN5 of an HB-510, DIP Switch settings must be set to ensure compatibility.
- DIP Switch 1-4 SPEED BLOCK L must be OFF. This will prevent the communication of the SPEED signal to/from CN5 on the HB-510. If not set, this signal will pull the speed signal in the HB-508S low and thus prevent the HB-508S to run at full speed.
- PIN 7 (DIR) on the communication cable must be removed. This will prevent the communication of the DIR signal to/from CN5 on the HB-510. If not removed, this signal will be pulled low and thus activated due to the signal voltage level difference of the HB-508S.
- PIN 8 (E-STOP) on the communication cable must be removed. This will prevent the communication of the ESTOP signal to/from CN5 on the HB-510. If not removed, this signal will be pulled low and thus activated due to the 0V present from the HB-508S GND connection.

Attention:

Option 2 or 3 may be used when connecting a chain of HB-508S cards to a chain of HB-510 cards. However, if an HB-510 card(s) is in between a chain of HB-508S cards, both Option 2 & 3 must be used. Because this may lead to confusion as to DIP switch settings and cable configuration, Option 1 is strongly recommended for all cases.

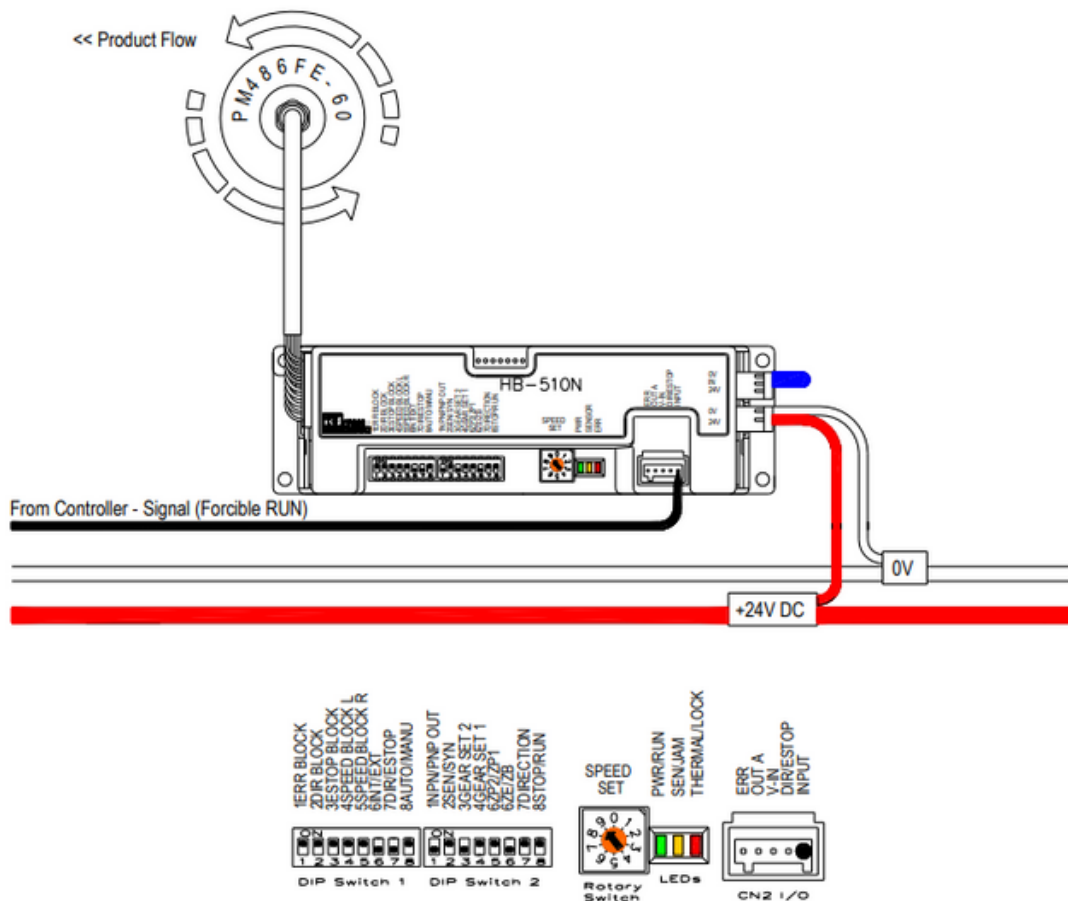

- When using an HB-510 as a standard driver or slave card, the above setting should be used.
- DIP switch 2-6 is set to OFF (ZE) – this setting bypasses the normal ZPA logic operations
- DIP switch 2-8 is set to ON (RUN) – this setting allows the active signal accepted at CN2-5 (INPUT) to command the motor to operate.
- Motor RUN signal applied to CN2-5 – this is the signal necessary to tell the motor to RUN
- Connect Sensor IN (CN3-2) to 0V (CN3-3) for NPN – this connection provides a continuous sensor signal to the card. It fools the card into thinking there is an occupied zone. Therefore, upon initial power ON, the card will not RUN the motor automatically. Connect Sensor IN (CN3-2) to 24V (CN3-1) for PNP.

Revision Number	Change
05-0725	Initial document
05-0902	Updated photograph on page 1
05-0923	Added "Internal Switches" section on page 4
06-0303	Many changes, new layout design Added "Features" to page 1 Added "Table of Contents" to page 2 Added drawings for DIP switches and configurations on pages 3, & 13-16 Added "Installation Precautions" on pages 5 & 6 Updated and clarified descriptions for switch settings on pages 7-12
06-0417	Updated document to clarify connection with HB-508S showing cable and DIP switch configurations Updated document with drawings for connector and cable information
07-0716	Changed photograph with new one showing grounding screw Updated documentation to reflect grounding instructions on page 8 Added warning not to confuse communication PIN assignment with Ethernet PIN assignment Added drawing to show names and locations of jumpers on page 13 Updated LED indication with visual aids on page 14
07-0724	Added standard/slave drive card instructions and drawings
07-0829	Updated instruction for communicating between HB-510 and HB-508S revising DIP switch settings and cable modifications
08-0110	Added "Revision History" to document
08-0609	Changed card drawing, page 3
08-0623	Changed label, definition of ZP1 to slug, ZP2 to singulation. Updated drawings.
08-0924	Updated documentation to show errors which can be reset by a signal to CN2-1 (INPUT), page 14
09-0423	Added precautions
12-0627	Updated page 14, NPN PNP switches. Updated page 15, added low voltage to "open fuse" error indications
13-0326	Updated specifications to auto-sensing inputs
13-0514	Removed auto-sensing feature
14-1120	Updated NPN/PNP inputs
16-0107	Corrected CN-2 pin descriptions. Removed Comm cable/Ethernet cable pin note p.5,21, 22, 23
19-0108	Updated company address
19-0904	Complete rework of design and layout
20-0130	Corrected references in text made to CN2 pins in order to reflect changes made to CN2 pin descriptions in 16-0107.