

CB-018N2

Driver Card Manual



FEATURES:

- Acceleration and deceleration control
- Stable speed operation
- Variable speed control with dip switches or by external signal inputs for up to 8 speeds
- Forcibly stops the motor if motor lock or overload errors occur
- Two (2) LEDs (red & green) to identify the status and errors
- Lead free design; RoHS compliant
- Low Voltage Protection reacts when
 - Sustained low voltage (less than 17V DC) for at least 1 second
- Error signal output
- External Direction control for reversing applications

Specifications subject to change without notice

SUBJECT	PAGE
Features	1
Specifications -Dimensions -Connections -Control Wiring	3-6
Operation -DIP Switches -Speed Change Table	6-7
LED and Error Indications	8
Installation Precautions	9
Revision History	10

DIMENSIONS:

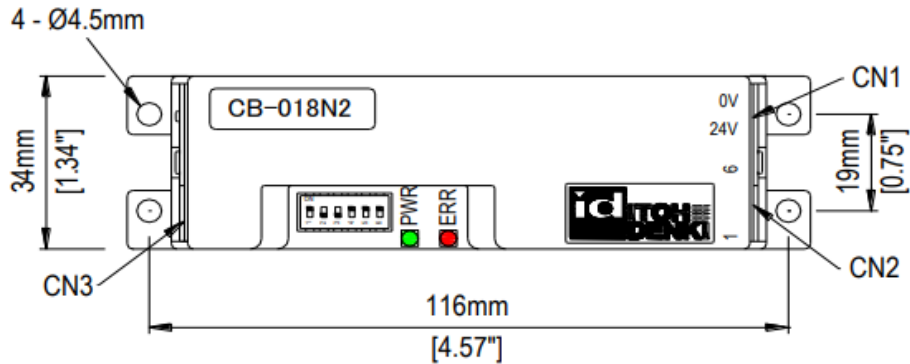

CONNECTIONS:

CN1 2 PIN Connector POWER		Male Connector on Card WAGO #734-162	Female Connector for Wiring WAGO #734-102
PIN	Description		
1	+24V DC	Wire Size 28~14AWG	
2	0V		

CN2 6 PIN Connector CONTROL		Male Connector on Card WAGO #733-366	Female Connector for Wiring WAGO #733-106
PIN	Description		
1	RUN (NPN)	Wire size: 28~20AWG	
2	DIR (PNP)		
3	Speed Selection Inputs (NPN) Refer to Speed Change Table on page 6		
4			
5			
6	Error Output (NPN)		

CONNECTIONS (CONTINUED):

CN3		Male Connector on Card JST #S3B-XH-A	Female Connector for Wiring JST #XHP-3
3 PIN Connector for Motor			
PIN	Description		
1	Motor Phase U - Red	Wire size: 24~22AWG Terminal Pins: JST #SXH-001T-PO.6	
2	Motor Phase V - White		
3	Motor Phase V - Black		

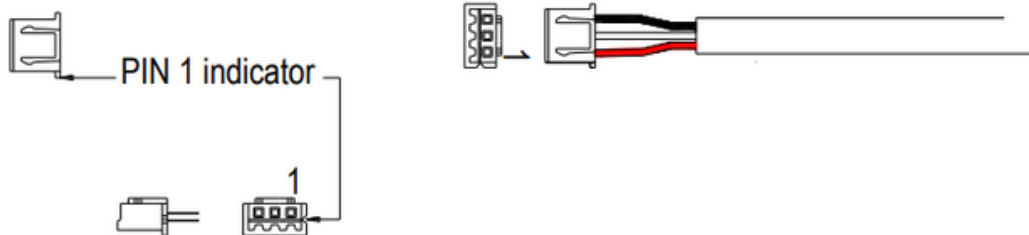

CONTROL WIRING

- Power to CN1 (24V DC) remains ON, control motor through CN2 (NPN signals only)

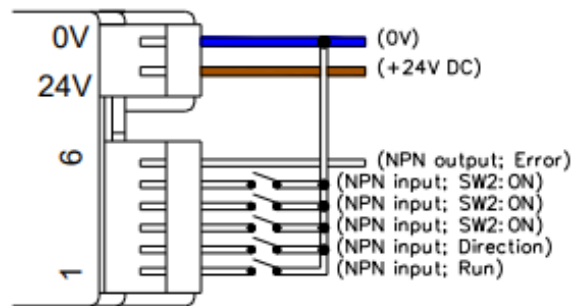

Press down spring clamp in connector with a small screwdriver.

Insert leads in proper order.

Lead should be stripped approx:
0.31~0.35"

WAGO connector (included) must be inserted and/or pulled out carefully, so as not to damage other parts.

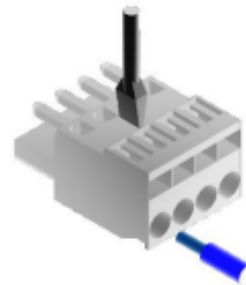

ELECTRICAL: 24V DC $\pm 10\%$ input
- Battery
- Power Supply: fullwave rectified with smoothed current and $<10\%$ Ripple
Power ON delay $<1s$
2.2A locking current Input signal level for activation
- 0V (3V or less) NPN
Output (Error) signal
- Open collector 35V, 25mA or less
- NPN

APPLICABLE MODELS: PM320HS

BRAKE: Dynamic (Electric)

PROTECTION: Thermal protection reaction
- $75^{\circ}C$ ($167^{\circ}F$) on the PCB
Built-in 5A fuse for power supply protection
Built-in diode for incorrect wiring protection

ENVIRONMENT: Temperature $0\sim 40^{\circ}C$ ($32\sim 104^{\circ}F$)
 $<90\%$ Relative Humidity (No condensation)
No corrosive gas
Vibration $<0.5G$

DIP SWITCHES - USER SETTINGS:

DIP-SW	Function	ON Setting	OFF Setting	Initial Setting
1	Accel/Decel	1 sec accel 1 sec decel	Starts/stops with signal timing	ON
2	Speed selection input	External (Input CN2-3, 4 & 5)	Internal (DIP switches 3-5)	OFF
3	Direction*	CW	CCW	OFF
4	Speed Selection	Refer to table below		ON
5				ON
6				ON

*Direction cannot be changed while run signal is active.

SPEED CHANGE TABLE:

■ (Default ON, ON, ON highest speed)

1	2	3	Nominal Speed (FPM)	Initial Setting
SW1-4 CN2-3	SW1-5 CN2-4	SW1-6 CN2-5		
OFF	OFF	OFF	19.0	All switches set ON
OFF	OFF	ON	32.5	
OFF	ON	OFF	42.7	
OFF	ON	ON	52.2	
ON	OFF	OFF	61.7	
ON	OFF	ON	72.2	
ON	ON	OFF	81.0	
ON	ON	ON	94.5	

LED 1: Green (power)

LED 2: Red (error condition)

Status	LED 1 (Green)	LED 2 (Red)	Error Condition*	Result
Normal operation	●	○	-	Normal
No power	○	○	-	Supply power (24V DC)
Motor Run	Flashes (1Hz) ● ○	○	-	Motor is running normally (See Note)
Fuse blown or low voltage (<17V)	○	Flashes (1Hz) ● ○	Current overload or $\leq 17V$	Card must be replaced or supply stable 24V DC
High current (while running)	Flashes (1Hz) ● ○	Flashes / OFF ●●●●●● (2 sec) ○○○○○○ (2 sec)	1 -1.5 A (Run signal ON $\leq 12s$)	May indicate overload during operation
High current (while running)	Flashes (1Hz) ● ○	Flashes (6Hz) ●●●●●● ○○○○○○ ●●●●●●	1 -1.5 A for $\geq 12s$ or $\geq 1.5 A$ for 4s	May indicate overload during operation, motor stops
Low voltage (<17V) and high current	○	Flashes / OFF ●●●●●● (0.4s) ● (0.6s)	$\leq 17V$ DC and 1 -1.5 A for $\geq 12s$ or $\geq 1.5 A$ for 4s	Motor stops
Thermal protection**	Flashes (1Hz) ● ○	●	PCB reached thermal limit	Motor stops 1s after reaction
Motor lock or motor not plugged in	Flashes (1Hz) ● ○	Flashes (1Hz) ● ○	Motor does not turn for 1s or motor is unplugged	Motor stops

Note: Green LED flashes when the RUN input signal is active, even during an error condition

*To reset an error condition: Remove all input signals; then reapply an input signal to CN2-1 (RUN). The red LED error condition will not reset until run signal is re-applied.

**Thermal protection can only be reset once the card reaches operating temperature. If the reset is attempted while thermal protection is active the motor will stop 1s after run signal is applied and red LED will illuminate again.



IMPORTANT: PLEASE READ BEFORE INSTALLATION

Precaution	Action	Reason
Power supply	If the power supply is not sized appropriately for the number of cards/rollers it provides power to, then a low voltage condition may occur.	<ul style="list-style-type: none"> • If the voltage drops below 15V DC and remains low for 1s, then the low voltage error will appear. • If the voltage drops below 15V DC five times in 0.5s, then the low voltage error will appear. • If the voltage drops below 15V DC less than five times in 0.5s or does not remain low for 1s, the roller may stutter – quickly turning off then on.
Multiple power supplies	0V line of all power supplies on the same conveyor line (powering the card/rollers, & controls) need to be physically linked together	This completes the signal path from one section of the conveyor (powered by a power supply) to the adjacent section of conveyor (powered by another power supply) and allows for proper communication through the cable and external interfaces.
Voltage drop across the power bus	Use suitable gauge wire in relation to distance and current draw to prevent voltage drop. Operating DC voltage is 24V ±10%	When running long distances from a DC power supply, the voltage drop during motor operation across the power bus may be significant (may drop below 15V). If there is a large enough drop in voltage, the roller(s) may behave in a strange manner. In order to prevent this, a larger gauge wire must be used.
Grounding	Ensure the control card is securely grounded to the conveyor frame. The conveyor frame should also be at the same potential reference as earth ground. Standard grounding practices should be followed.	Static discharge may interfere and damage internal components.
Electrical	24V DC ±10% 4A maximum current limiter (motor lock is 4A) Diode protection for miswiring Sensor power short circuit protection 5A fuse for power supply protection	Improper power will damage the card. The motor/ card should not be subject to locked conditions repeatedly. Internal fuse is not replaceable. If the fuse has blown, more serious damage has occurred within the card/motor
Environment	Ambient temperature is 32~104°F Ambient humidity is < 90% RH Atmosphere has no corrosive gas Vibration is < 0.5G - Indoor use only	Extreme environmental variables may cause poor or no performance and damage the card.
Over-Speeding	Over-speeding of the roller's no-load speed by more than 50% may cause damage.	Back EMF will be generated.

Revision Number	Change	Created By:	Checked By:
15-0716	Initial document	BB	KN
19-0603	Address update	BH	BB