

CB-016S4 & CB-016BS4 Circuit Board



Features

- Adjustable acceleration and deceleration time (0 to 2.5s)
- Stable speed operation
- Switch for manual or automatic recovery of the thermal overload device
- One (1) DIP switch combined with one (1) rotary switch to select up to 20 different fixed speeds
- DIP switch to select the condition of error signal activity; during normal status or abnormal status
- Forcibly stops the motor if motor lock or thermal overload error lasts for 4 seconds or more.
- Three (3) LEDs (green, red, & orange) to identify the type of error and number of error occurrences
- Pulse signal output to indicate motor revolution
- Lead free design; RoHS compliant

Enhancements from CB-016S2

- Improved Low Voltage Protection reacts when
 - Sustained low voltage (less than 15V DC) for at least 1 second
 - Fluctuating voltage dropping below 15V DC, 5 times within 0.5 second
- Delayed start-up Over-current response
 - 1 second delay after RUN signal is applied, before over-current indication is active
 - Eliminates false over-current indication during motor start
- Error occurrence indication
 - Displayed only when error condition is present
- Improved external Direction control
 - When external DIR signal is changed while motor is running, the motor stops for 0.5 second, then runs again in opposite direction

SPECIFICATIONS SUBJECT TO CHANGE WITHOUT NOTICE

SPECIFICATIONS

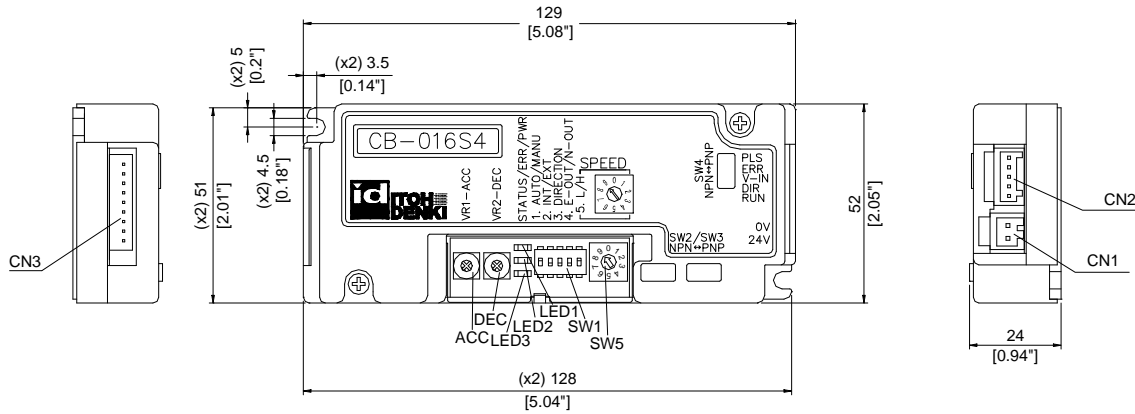

Electrical

- 24V DC $\pm 10\%$ input
 - Battery
 - Power Supply: fullwave rectified with smoothed current and $< 10\%$ Ripple
- Power ON delay $< 1s$
- 4A locking current
- Input signal level for activation
 - 0V (3V or less) for NPN
 - 24V (18V or greater) for PNP
- Output (Error and Motor Pulse) signals
 - Open collector 24V, 25mA or less
 - NPN
 - PNP (selectable for Error only)
- Brake model only
 - 0.2s delay between stop signal and mechanical brake reaction
 - 0.2A brake current @24V ($< 0.1s$)
 - Brake coil is active (disengaging brake) while motor is running

Applicable PM Models

- PM486/500FS
- PM486/500/570FE
- PM486/500FP
- PM635FS

Brake

- Dynamic (Electric – Both models)
- Mechanical (CB-016BS4 only)

SPECIFICATIONS SUBJECT TO CHANGE WITHOUT NOTICE

SPECIFICATIONS

Protection	Thermal protection reaction <ul style="list-style-type: none">- 85°C (185°F) on the PCB- 105°C (221°F) in the motor Built-in 5A fuse for power supply protection Built-in diode for incorrect wiring protection	
Terminal	2-Pole WAGO (CN1) <ul style="list-style-type: none">- (M) 734-162- (F) 734-102	5-Pole WAGO (CN2) <ul style="list-style-type: none">- (M) 733-365- (F) 733-105
Motor Connector	9-Pole JST (CB-016) <ul style="list-style-type: none">- (M) S9B-XH-A- (F) XHP-9 (socket terminal SXH-001P-P0.6)	10-Pole JST (CB-016B) <ul style="list-style-type: none">- (M) S10B-XH-A- (F) XHP-10 (socket terminal SXH-001P-P0.6)
Applicable Environment	Temperature 0~40°C (32~104°F) <90% Relative Humidity (No condensation) No corrosive gas Vibration <0.5G	

SPECIFICATIONS SUBJECT TO CHANGE WITHOUT NOTICE

OPERATION

DIP Switches – User Settings

DIP-SW	Function	ON setting	OFF setting	Initial setting
1	Thermal device recovery	Manual	Automatic (Restarts 1min after cool down)	ON
2	Speed change selection	External (0~10V DC applied) See Speed Change Tables	Internal (DIP & Rotary switches)	OFF
3	DIR* (no external DIR signal; viewed from cable side)	FS/FP – CCW FE – CW	FS/FP – CW FE – CCW	OFF
4	Error signal activity	Active during normal status	Active during abnormal status	ON
5	Internal speed change	High speed Refer to table on page 7	Low speed	ON
Rotary	Internal speed change	Refer to table on page 7		9

*If a direction change signal should occur while the motor is running, the motor will first stop for 0.5s. Then, the motor will start in the new direction.

Potentiometers*

VR1 – Acceleration

Adjust acceleration time from 0~2.5s after the RUN signal is applied

VR2 – Deceleration

Adjust deceleration time from 0~2.5s after the RUN signal is removed

* VRs turn 270°

Internal Switches*

Switch	Function	Position for Signal Type		Initial Setting
		NPN Setting	PNP Setting	
SW2	RUN Input	LEFT	RIGHT	LEFT
SW3	DIR Input	LEFT	RIGHT	LEFT
SW4	ERR Output	DOWN	UP	UP

* These switches are not readily visible. They are under the cover, protected by seals on the cover. Access them by removing the seals. Then, toggle the switches, and replace the seals.

The following input/output settings are available from the factory, if necessary:

Alternate Model Designation

CB-016N4 – NPN input <u>and</u> output signals CB-016P4 – PNP input <u>and</u> output signals CB-016BN4 or CB-016BP4 – for brake models, respectively

SPECIFICATIONS SUBJECT TO CHANGE WITHOUT NOTICE

LED and ERROR Indications

LED 1 – Green (power)

LED 2 – Red (error condition)

LED 3 – Orange (error occurrence)

LED Error Indication

Status	LED 1 (Green)	LED 2 (Red)	ERR Output (DIP-SW4 setting)		Error Condition*	Result
			OFF	ON		
Normal operation	●	○	○	●	-	-
No power	○	○	○	○	-	Supply power (24V DC)
Fuse blown	○	Blinks (6Hz) ●●●●○ ●●●●○	●	○	Current overload	Card must be replaced
Current limit (while running)	●	Blinks (6Hz) ●●●●○ ●●●●○	○	●	Maximum current (Run signal ON >1s)	May indicate overload during operation
Low voltage (<15V)	●	Blinks (6Hz) ●●●●○ ●●●●○	●	○	≤15V DC (>1s or 5x in 0.5s)	Motor does not operate
Thermal protection**	●	●	●	○	Motor or PCB overheated	Motor stops 4s after reaction
Motor lock	●	Blinks (1Hz) ● ○	●	○	Motor does not turn for 4s	Motor stops
Motor not plugged in	●	●	●	○	-	Motor does not operate

*To reset an error condition: Remove input signals; then reapply an input signal to either CN2-1 (RUN) or CN2-2 (DIR)

**If thermal device recovery is set for automatic, the error will reset 1 min after the temperature has reached operating range, and as long as no external input has been applied.

Red LED Indication – Error condition

The red LED indicates the **present** error condition in conjunction with the green LED.

No Error	Motor Lock	Low Voltage (<15V)	Fuse Blown*	Current Limit*	Thermal Protection
○	Blinks (1Hz) ● ○	Blinks (6Hz) ● ○ ● ○ ● ○ ● ○ ● ○ ● ○	Blinks (6Hz) ● ○ ● ○ ● ○ ● ○ ● ○ ● ○	Blinks (6Hz) ● ○ ● ○ ● ○ ● ○ ● ○ ● ○	●

Orange LED Indication – Error occurrence

The orange LED indicates the number of **consecutive** occurrences of the **present** error condition indicated by the red LED. If the previous error differs from the present error, a combination status will be displayed. This is only displayed while an error condition is active.

No Error	1	2	≥3	Combination
○	○	Blinks (1Hz) ● ○	●	Blinks (6Hz) ● ○ ● ○ ● ○ ● ○ ● ○ ● ○

* The occurrences of “fuse blown” and “current limit” errors are not recorded.

Motor pulse output signal

NPN (0V) output from CN2-5
Two (2) pulses per motor revolution

Speed Change Table

Speed Adjustment Control Method Discreet Steps			Surface Speed* ft/min ±3%		
Internal Control Switches		External Control 0~10V DC	PM486FE-17 (3-stage)	PM486FE-60 (2-stage)	PM486FE-100 (1-stage)
DIP sw5	Rotary				
ON	9	9.55~9.95	55.4	196.8	408.0
	8	9.05~9.45	50.5	180.4	408.0
	7	8.55~8.95	48.2	172.2	408.0
	6	8.05~8.45	45.9	164.0	408.0
	5	7.55~7.95	43.6	155.8	408.0
	4	7.05~7.45	41.3	147.6	408.0
	3	6.55~6.95	36.7	131.2	408.0
	2	6.05~6.45	34.4	123.0	408.0
	1	5.55~5.95	32.1	114.8	408.0
	0	5.05~5.45	29.8	106.6	378.8
OFF	9	4.55~4.95	27.6	98.4	349.6
	8	4.05~4.45	25.3	90.2	319.5
	7	3.55~3.95	23.0	82.0	291.3
	6	3.05~3.45	20.7	73.8	262.1
	5	2.55~2.95	18.4	65.6	233.2
	4	2.05~2.45	16.1	57.4	204.0
	3	1.55~1.95	13.8	49.2	174.8
	2	1.05~1.45	11.5	41.0	145.6
	1	0.55~0.95	9.2	32.8	116.4
	0	0.05~0.45	6.9	24.6	87.6

* The listed speed steps are based on our 1.9" (48.6mm) diameter roller tube, FE motors, and 3 different gear stages. Shaded speeds represent no-load speeds. Any speed settings (for the corresponding gear stage) above the model's maximum speed will have no effect. Also, FS and FP models will operate slightly faster.

SPECIFICATIONS SUBJECT TO CHANGE WITHOUT NOTICE

WIRING

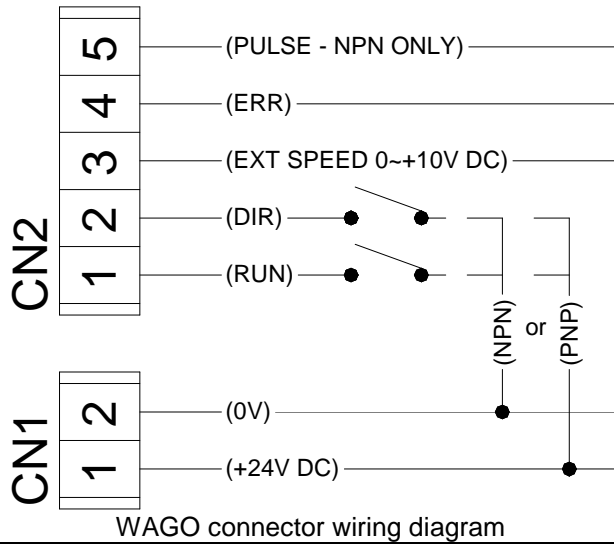

CN2 – Control Signals

External Speed Signal*
(0 ~ +10V DC)

NPN – 0V signal to operate
PNP – +24V DC signal to operate

CB-016S4 is set for **NPN** inputs and **PNP** ERR output

CB-016N4 is set for **NPN** inputs and **NPN** ERR output

CB-016P4 is set for **PNP** inputs and **PNP** ERR output

*Terminal CN2-3 is used only when PM speed is to be controlled by an external DC voltage

<p>CN1 – POWER CONNECTOR WAGO connector # 734-102 Minimum wire gauge – 28 AWG Maximum wire gauge – 16 AWG</p>	<p>CN2 – CONTROLS CONNECTOR WAGO connector # 733-105 Minimum wire gauge – 28 AWG Maximum wire gauge – 20 AWG</p>
--	---

Press down spring clamp in connector with a small screwdriver.

Insert leads in proper order.

Lead should be stripped approx: 0.31~0.35"

WAGO connector (included) must be inserted and/or pulled out carefully, so as not to damage other parts.

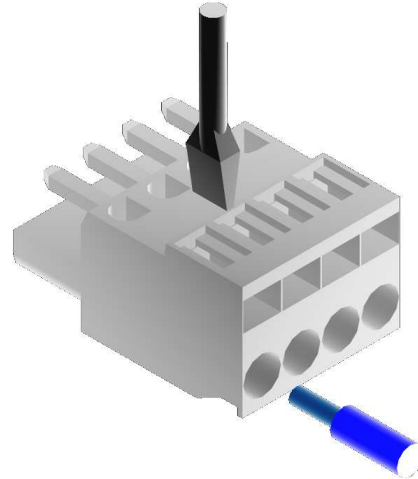

SPECIFICATIONS SUBJECT TO CHANGE WITHOUT NOTICE



Installation Precautions – IMPORTANT, PLEASE READ BEFORE INSTALLATION

Precaution	Action	Reason
Power supply	If the power supply is not sized appropriately for the number of cards/rollers it provides power to, then a low voltage condition may occur.	<ul style="list-style-type: none"> - If the voltage drops below 15V DC and remains low for 1s, then the low voltage error will appear - If the voltage drops below 15V DC five times in 0.5s, then the low voltage error will appear - If the voltage drops below 15V DC less than five times in 0.5s or does not remain low for 1s, the roller may stutter – quickly turning off then on
Multiple power supplies	0V line of all power supplies on the same conveyor line (powering the card/rollers, & controls) need to be physically linked together.	This completes the signal path from one section of the conveyor (powered by a power supply) to the adjacent section of conveyor (powered by another power supply) and allows for proper communication through the cable and external interfaces.
Voltage drop across the power bus	Use suitable gauge wire in relation to distance and current draw to prevent voltage drop. <u>Operating</u> DC voltage is 24V ±10%	When running long distances from a DC power supply, the voltage drop during motor operation across the power bus may be significant (may drop below 15V!). If there is a large enough drop in voltage, the roller(s) may behave in a strange manner. In order to prevent this, a larger gauge wire must be used.
Grounding	Ensure the control card is securely grounded to the conveyor frame. The conveyor frame should also be at the same potential reference as earth ground. Standard grounding practices should be followed.	Static discharge may interfere and damage internal components.
Electrical	24V DC ±10% 4A maximum current limiter (motor lock is 4A) Diode protection for miswiring Sensor power short circuit protection 5A fuse for power supply protection	Improper power will damage the card. The motor/card should not be subject to locked conditions repeatedly. Internal fuse is not replaceable. If the fuse has blown, more serious damage has occurred within the card/motor.

SPECIFICATIONS SUBJECT TO CHANGE WITHOUT NOTICE

Page 9 of 10



Installation Precautions – IMPORTANT, PLEASE READ BEFORE INSTALLATION

Environment	Ambient temperature is 32~104°F Ambient humidity is < 90%RH Atmosphere has no corrosive gas Vibration is < 0.5G Indoor use only	Extreme environmental variables may cause poor or no performance and damage the card.
Over-speeding	Over-speeding of the roller's no-load speed by more than 50% may cause damage.	Back EMF will be generated.

Revision History

Revision Number	Change
08-0930	Initial document
08-1016	First page, show enhancements from CB-016S2
08-1028	Page 1 & 6, clarified the indication of error occurrence (orange LED)
09-0423	Added precautions

SPECIFICATIONS SUBJECT TO CHANGE WITHOUT NOTICE